

COMSATS University Islamabad  
Sahiwal Campus

**TENDER DOCUMENTS**

**For**  
**Procurement of Furniture & Fixture for Research Center of CUI Sahiwal**  
**Campus**

**(Single Stage Two Envelop Procedure)**

**Submission and Opening Date for Tender:**

**January 20, 2023 (Friday)**

**Submission Time for Technical and Financial Proposals: 1400 hours**

**Opening Time (only Technical Proposals): 1430 hours**

**Tender Issued to M/s \_\_\_\_\_**

**January 2023**



**Purchase and Store Department**

COMSATS Road, Off G.T.Road, Sahiwal

Tel: 040-4305666-Ext-128 & 186

Web: <https://www.sahiwal.comsats.edu.pk/Tenders.aspx>

**Signature & Stamp of Bidder**

### **Invitation to Bid**

(Tender No. CUI/SWL/Procurement/FY 22-23/11/162)

#### **Procurement of Furniture & Fixture for Research Center of CUI Sahiwal Campus Tender No. 162.**

1. COMSATS University Islamabad, Sahiwal Campus, a public sector organization invites sealed bids from the reputed firms/authorized distributors/general order suppliers registered with income and sales tax departments and who are on active taxpayers list (ATL) of FBR for the work titled “**Procurement of Furniture & Fixture for Research Center of CUI Sahiwal Campus**”.
2. The procedure of open competitive bidding is **Single Stage-Two Envelope**.
3. Bidding documents, which are containing detailed terms and conditions, method of procurement, procedure for submission of bids, bid security, bid validity, opening of bid, evaluation criteria, clarification/rejection of bids, performance guarantee etc. are available for the interested bidders at “Purchase and Store Department, COMSATS Road, Off G.T.Road, Sahiwal”. The non-refundable fee of bidding document is **Rs. 1,000 (One Thousand Rupees Only)** in shape of pay order/Demand Draft in favor of CUI, Sahiwal.
4. Security deposit of **Rs: 80,000/** is required to furnish in the form of Bank deposit / CDR / Pay order (refundable) as a Bid Security in favor of “COMSATS University Islamabad, Sahiwal Campus”. Any bid which is not accompanied along with bid security shall be rejected by the CUI, Sahiwal as non-responsive and without any right of appeal.
5. The bids, prepared in accordance with the instructions in the bidding documents, must reach Purchase and Store department, COMSATS Road, Off G.T.Road, Sahiwal on or before 1400 hours on **January 20, 2023 (Friday)**. Bids will be opened at 1430 hours on the same day, in the presence of bidder’s representatives who choose to attend at the same address. This advertisement is also available on the PPRA website at [www.ppra.org.pk](http://www.ppra.org.pk) and on the Campus Website at <https://sahiwal.comsats.edu.pk/Procurement/Tenders.aspx>

**Muhammad Umar Irshad**  
**In-charge Purchase and Store Department**  
**Cell No: 0300-6907240**

**Signature & Stamp of Bidder**

## TERMS AND CONDITIONS OF THE TENDER

1. **Eligible Bidders.** - Bidding is open to all firms and persons meeting the following requirements:
  - a) Registered with Income and Sales Tax Departments, Government of Pakistan
  - b) and who are on Active Taxpayers List (ATL) of Federal Board of Revenue (FBR), Government of Pakistan.
  
2. **Tender Document Fee (Non-Refundable).** - Bidding documents along with Pay Order / Demand Draft amounting to **Rs. 1000/-** as a tender documents fee (Non-Refundable) shall be submitted in favor of COMSATS University Islamabad, Sahiwal Campus to the address given below. No bid will be accepted without tender documents' fee. Attach tender document fee with Technical Proposals.
  
3. **Bid Security (Refundable).** - Security deposit of **Rs: 80,000/** is required to furnish in the form of Deposit at Call (CDR) or a Bank Guarantee issued by a Scheduled Bank in Pakistan as a Bid Security in favor of "COMSATS University Islamabad, Sahiwal Campus. Any bid not accompanied by an acceptable bid security shall be rejected by the Employer as non-responsive and without any right of appeal. Attach Earnest money with Financial Proposals.
  - a. The bid securities of unsuccessful bidders will be returned upon award of contract/Issuance of Purchase Order to the successful bidder or an expiry of validity of Bid Security whichever is earlier.
  
  - b. The Bid Security may be forfeited:
    - i. If a bidder withdraws his bid during the period of bid validity
    - ii. If a bidder does not accept the correction of his bid price
    - iii. in case of a successful bidder, if he fails to sign the contract agreement or execute the work as specified in bill of quantities (BoQ).
  
4. **Performance Guarantee (Refundable):** The Warranty is one year. However, 05% of the total value of the Invoice or a Bank Guarantee issued by a Scheduled Bank in Pakistan will be retained as security by COMSATS University Islamabad, Sahiwal Campus which will be released after one year from the date of delivery / completion of work / supply. Insurance Guarantee is not acceptable. After finalization of the bid and signing contract performance guarantee is required to be submitted and bid security is to be released.
  
5. **Bid validity.** - All prices should be valid for at least **90 days.** Withdrawal or any modification of the original offer within the validity period shall entitle CUI to forfeit the

earnest money in favor of the CUI and / or put a ban on such vendor participation in CUI tenders / works

6. All prices should be quoted on F.O.R (Pak Rupees).
7. **Delivery time or Completion Schedule.** - The exact completion/delivery time from the date of the purchase / work order will be **30 days**. The handing over / completion time for this contract is of critical importance.
8. The bid proposal should be inclusive of freight and all other taxes and we need delivery of items at COMSATS University Islamabad, Sahiwal Campus's premises.
9. All pages (BoQs & Terms & Conditions) are mandatory to be signed / stamped, failing which the bid may be rejected
10. Any addition, deletion or modification of any clause of the procurement terms & conditions of CUI by any vendor will not be acceptable and may lead to rejection of the bid.
11. **Site Visits/Concerned Office.** - Before quoting, the Bidder in his own interest can visit the **Store Section of CUI Sahiwal Campus/Concerned Office for sample/specifications/requirements of each item** and to know the full implications of the assignment. This will help him in proper assessment of the work. Failure to do so will not absolve the contractor of his responsibility to carry out the work as specified in the tender documents. The cost of visiting the site shall be borne by the Tenderer and shall be at his own responsibility and risk.
12. The bid form (BoQs) must be duly filled in, stamped and signed by the authorized representative of the bidder.
13. **Method of Procurement.** – COMSATS University Islamabad, Sahiwal Campus, will follow the PPRA rule of **single stage two envelope procedure**;
  - i. The bid shall comprise a single package containing **Two Separate Envelopes**. Each envelope shall contain separately the **Financial Proposal** and the **Technical Proposal**;
  - ii. The envelopes shall be marked as **“FINANCIAL PROPOSAL”** and **“TECHNICAL PROPOSAL”** in bold and legible letters to avoid confusion;
  - iii. Initially, only the envelope marked **“TECHNICAL PROPOSAL”** shall be opened;
  - iv. The envelope marked as **“FINANCIAL PROPOSAL”** shall be retained in the custody of the procuring agency without being opened;

- v. The procuring agency shall evaluate the technical proposal in a manner prescribed in advance, without reference to the price and reject any proposal which does not conform to the specified requirements;
- vi. During the technical evaluation no **amendments** in the technical proposal shall be permitted;
- vii. The financial proposals of bids shall be opened publicly at a time, date and venue announced and communicated to the bidders in advance;
- viii. After the evaluation and approval of the technical proposal the procuring agency, shall at a time within the bid validity period, publicly open the financial proposals of the technically accepted bids only. The financial proposal of bids found technically nonresponsive shall be returned un-opened to the respective bidders;
- ix. and the bid found to be the lowest evaluated bid shall be accepted.

**14. Submission and Opening of bids.** - The bid should be submitted in a sealed envelope in such manner that the contents are fully enclosed and cannot be known until duly opened. The sealed bids (Technical and Financial Proposals) must reach up to **January 20, 2023 (Friday)** on or before **1400 hours** and will be opened on the same date **at 1430 hours** in the presence of available bidders. All bids submitted after the time prescribed shall be rejected and returned without being opened.

**15.** The envelope should be marked as under;

**Secretary, Purchase Committee**  
**COMSATS University Islamabad, Sahiwal Campus**  
COMSATS Road, Off G.T Road, Sahiwal.  
Tel: 040-4305001-05, Ext: 128

The envelope shall also bear the word “CONFIDENTIAL” and following identification quotation of “**Procurement of Furniture & Fixture for Research Center of CUI Sahiwal Campus**”.

**16.** After opening of bids, COMSATS University Islamabad, Sahiwal Campus will examine the bids for completeness as per tender document.

**17. Evaluation Criteria:** Technical bids will be evaluated on the basis of following criteria:

- Tender will be evaluated on **Item Wise Basis** for Part-A and also **Item Wise Basis** for Part-B.
- The bidder can participate in one part OR in both parts of the tender.

- The bidder will **provide sample and literature of quoted brands** which will be evaluated as per specifications provided in tender documents.
- Complete Company profile with HR Strength, National and General Sales Tax Numbers, year of establishment and client lists.
- Experience of the firm for supplying of Furniture/Fixture to any Federal or Provincial Government Department, Agency, Organization or autonomous body or Private Sector Organization anywhere in Pakistan. Please attach Purchase Orders/Work Orders with technical proposals.
- Tenderer is a bidder who has not been blacklisted by any Federal or Provincial Government Department, Agency, Organization or autonomous body or Private Sector Organization anywhere in Pakistan. The vendor will provide this undertaking on judicial stamp paper with Technical Proposal.

**18. Evaluation of bids.** - Bids will be evaluated in accordance with the evaluation criteria and other terms and conditions set forth in the bidding documents.

**19. Clarification of bids.** - After opening of bids, bidders are not allowed to alter or modify his bid. However, the procuring agency may seek and accept clarifications to the bid that do not change the substance of the bid.

**20.** The Tender shall be checked for any arithmetic errors which shall be rectified. The Tender Price as determined after arithmetic corrections shall be termed as the Corrected Total Tender Price which shall binding upon the Tenderer.

**21. One Bid per Bidder.** - Conditional or alternative bids are not allowed. Bidders are required to quote one bid/one brand. If bidders quote two bids/different brands then their bids are liable to be rejected.

**22.** COMSATS University Islamabad, Sahiwal Campus reserves the rights to reject the bid if;

- i. Received without earnest money
- ii. Received later than the date and time fixed for tender submission
- iii. The tender is unsigned/ unstamped
- iv. The offer is ambiguous
- v. The offer is conditional
- vi. Offer is made by the unauthorized agent/ supplier of the original equipment manufacturer.
- vii. The offer is from a firm, which is black listed by any Govt. Office.

- viii. The offer is received by telephone/telex/fax/telegram.
- ix. Any unsigned / ambiguous erasing, cutting / overwriting etc. is made.

- 23.** It is the sole responsibility of the agent / supplier / manufacturer to comply with the applicable laws, be national or international.
- 24.** Purchase order (s) will be awarded to the lowest or technically recommended bidder (s) on the basis of item wise / subtotal wise / grand total wise according to the nature of BoQs.
- 25. Rejection of bids.** - COMSATS University Islamabad, Sahiwal reserves all the rights to reject all bids or proposals at any time prior to the acceptance of a bid or proposals. CUI Sahiwal will communicate the grounds for rejection of bids upon request of any supplier or contractor but not liable to justify those grounds
- 26.** The contract will be executed and handed over in satisfactory conditions up to the entire satisfaction of COMSATS University Islamabad, Sahiwal Campus
- 27. If the vendor fails to deliver the goods / services to CUI-Sahiwal in time then the penalty will be charged as under: -**
- a. 0.5% per day of the Purchase Order for the first 10 working days.
  - b. 0.75% per day of the Purchase Order, after that, up to a maximum of 10% of sum stated in the Purchase/Work Order. Once the maximum is reached, the Purchaser may terminate the contract pursuant to tender clause 35, earnest money and payment may be forfeited.
- 28.** If the delivered goods / services are not according to the required quality standards / specifications, the same shall be liable to be rejected after inspection. The vendor would be required to supply as per requirements mentioned in our BoQs, otherwise the purchase / work order will be cancelled after due date with confiscation of earnest money.
- 29.** The Employer will inspect the supplied and provided items to verify their conformity to the Technical Specifications given in BoQ. The inspection will be conducted at final destination.
- 30. On account payments.** - Part / Advance payments are not allowed. Payment will be made on submission of Invoice in the name of “COMSATS University Islamabad, Sahiwal Campus” with a copy of delivery challan (s) after the complete order has been supplied, inspected and accepted which includes delivery / installation, and COMSATS acceptance / inspection thereof.
- 31.** Deduction of Income Tax and any other tax will be deducted at source according to Government prevailing rules.

- 32. Blacklisting of Suppliers and Contractors.** - A procuring agency can permanently or temporarily bar from participation in its respective procurement proceedings, the suppliers and contractors who either consistently failed to provide satisfactory performances or found to be indulging in corrupt or fraudulent practices.
- 33.** In case of any dispute, decision of the Director, CUI Sahiwal will be final and binding upon the parties.
- 34.** The quantities given in the Bill of Quantities are estimated and provisional, and are given to provide a common basis for bidding. The basis of payment will be the actual quantities of work executed and measured by the Bidder and verified by the Department/Concerned Office and valued at the rates and prices entered in the priced Bill of Quantities, where applicable, and otherwise at such rates and prices as the Employer may fix as per the Contract.
- 35.** The CUI reserves the right to modify the quantities of goods / services at any time before the award of purchase / work order.
- 36.** In case of repeat orders fifteen per cent (**15%**) of the Original Procurement will be considered as the permissible limit to issue variation.
- 37.** The bidder should furnish a certificate as worded below in token of acceptance of all the terms and conditions of the tender. Otherwise, the tender will not be considered under any circumstances.



38. I / We hereby confirm to have read carefully the terms and conditions of your Tender Enquiry dated for opening on..... for the purchase of .....

We agree to abide by all these terms and conditions/instructions.

39. Certified that the prices quoted against advertises tender dated..... are not more than the prices charged from any other purchasing agencies in the county in the financial year..... and in case of any discrepancy, We/I hereby undertake to refund the price charged in excess if and when asked to do so.

40. Certified that the prices quoted by our firm are inclusive of G.S.T and all taxes as per rules and regulations.

**Company / Vendor Name:**.....

**Name of Tenderer:**.....

**Postal Address:**.....

**Tel. / Mobile:**.....**Email:**.....

**NTN#:**.....**GST#:**.....

**C.N.I.C No:**.....

**Signature of Tenderer:**.....

**Date and Stamp:**.....

- Please also attach the Certificate supporting being Active Taxpayer as per requirement of FBR.

**Part-A-of the Tender**

**Bill of Quantities (BoQ) (Item Wise Basis) Sample will be Required with**

**Technical Proposal**

**Procurement of Furniture & Fixture for Research Center of CUI, Sahiwal Campus**

Sr.#	Item Name & Specification	Qty		Rates to be quoted inclusive of all taxes, installation and Delivery Charges		
				Quoted Model/Brand	Unit Price (Rs)	Total Price (Rs)
1	<b><u>Center Table</u></b> <b>Size:</b> 60L x 48W x 30H (inches) <b>Material:</b> Laminate <b>Base:</b> Metal leg <b>Top:</b> 17mm thick lamination (Natural veneer laminate) <b>Partition:</b> Fabric and 8mm Tempered Tinted <b>Finish:</b> Matt Black Powder Coated	No	05			
2	<b><u>Round Table for Six Persons</u></b> <b>Size:</b> 48 x 48 (Diameter) x 29 H (inches) <b>Base:</b> Matt Black Powder Coated and Chrome Legs <b>Top:</b> 17mm Thick Lamination (Natural Veneer Laminate and Brushed Oak Laminate) <b>Finish:</b> Brushed Oak Finish <b>Cable Cover:</b> Aluminum	No	02			
3	<b><u>Table for One Person</u></b> <b>Specifications:</b> <b>Material:</b> Laminate <b>Size:</b> 47 L x 24 W x 29 H (inches) <b>Base:</b> Metal leg <b>Top:</b> 17mm thick lamination (Natural veneer laminate) <b>Finish:</b> Matt black powder-coated	No	05			

**Signature & Stamp of Bidder**

4	<u><b>Books Shelves</b></u> Size: 48 L x 16 W x 84 H (Inches) Laminated UV Sheets with PVC Tape/Trim Powder Coated Pipe Frame 18mm x 18mm (To Support Shelves) Foot Cap 4 Inch	No	05			
5	<u><b>One White Board</b></u> Laminated White Board with PVC Trim Size 12' x 4'	No	01			
6	<u><b>Revolving Chair</b></u> Revolving Chair-In Black Color. <ul style="list-style-type: none"> <li>• Comfortable for Longer Time</li> <li>• Easily Movable</li> <li>• Strong Structure</li> </ul> (As Per Sample OR Equivalent)	No	20			
7	<u><b>Students Sitting Chairs</b></u> <ul style="list-style-type: none"> <li>• Mesh Back</li> <li>• Mesh Padded Seat</li> <li>• Lumbar Back Support</li> <li>• Black Painted Base</li> </ul> Size: 22 W x 22 D x 40 H (Inches)	No	17			
	<b>Grand Total (Rs.)</b>					
	<b>Grand Total in words including all taxes, Installation and Delivery Charges</b>					

**Note:**

- Vendor is suggested to visit the site before quoting the bid.

**Signature & Stamp of Bidder**

- Sample will be required with technical proposal
- The Purchase/Work order will be awarded on **Item Wise Basis.**
- Please clearly mention the quoted model/brand/technical detail otherwise your bid /items may be rejected.
- Bidders shall price the Bill of Quantities in Pakistani Rupees only.
- For all the Brands mentioned in this tender (if any), the term “or equivalent” is hereby added and shall be considered as per PPRA rules.
- Multiple prices of an item may lead to rejection of the item/bid.
- Please quote the rates on our BoQ otherwise your bid/item may be rejected or accepted.

**Part-B-of the Tender**

**Bill of Quantities (BoQ) (Item Wise Basis)**

**Procurement of Furniture & Fixture for Research Center of CUI, Sahiwal Campus**

Sr. #	Item Name & Specification	Qty		Rates to be quoted inclusive of all taxes Installation and Delivery Charges		
				Quoted Model/Brand	Unit Price (Rs)	Total Price (Rs)
<b>1</b>	<p><b><u>LED 85 Inches Android UHD</u></b></p> <p>LED 85 Inch Android UHD  <b>Size:</b> 85"  <b>Chassis:</b> RT51 M Platform  <b>CPU:</b> 64-bit A55×4~1.3GHz  <b>GP:</b> G31x2 800MHz  <b>OS:</b> Android R  <b>RAM/ROM:</b>                      DDR3-1866: 2G Bytes  <b>UI Style:</b> Android TV UI &amp; TV UI  <b>Power Consumption:</b> 85W  <b>Certification:</b> CB, Dolby Audio, Dolby Vision, HDMI, CTS (Google Official Certification), Netflix  <b>Display Type:</b>                      LED UHD Smart DTV  <b>Display Resolution:</b> 3840×2160  <b>UHD Support:</b> Yes  <b>HDR:</b> HDR10  <b>HDR Support:</b> Yes  <b>High Color Gamut:</b>                      ≥75% DCI-P3(CIE 1976)                      Coverage  <b>Micro Dimming:</b> 1296 zones  <b>Brightness (cd/m2):</b> 270 (typ.)  <b>Contrast Ratio:</b> 5000:1 (typ.)  <b>Response Time (G to G)</b></p>	<b>No</b>	<b>01</b>			

**Signature & Stamp of Bidder**

	<p>9.5 (typ.)  <b>Colors:</b>  1.07G (8 bit + FRC)  <b>Refresh Rate:</b> 60  <b>Dynamic Contrast:</b> Yes  <b>Backlight Adjustable:</b>  Off, ECO, Brightness+  <b>Internet Link:</b>  2.4GHz Wi-Fi 802.11 b/g/n 2T2R  Ethernet Network (RJ45)  <b>HDMI:</b> Yes  <b>HDMI&amp;HDCP Version:</b>  HDMI1.4 &amp; HDMI2.1, HDCP1.4  &amp; HDCP2.2  <b>HDMI Support:</b> Yes  <b>Cable Port:</b> Yes  <b>USB:</b> Yes  <b>A/V IN:</b> Yes  <b>Headphone:</b> Yes  <b>Accessories</b>  Remote Control (Standard),  Power Cable (Built In), Batteries  for Remote, User Manual, Base  Stand, Wall Mount Bracket, TV  with Stand  <b>LED Warranty</b>  <b>Warranty: Panel-Two (2) Years</b>  <b>Warranty: Parts-One (01) Year</b>  <b>Sony, Samsung, TCL OR</b>  <b>Equivalent</b></p>					
2	<p><b><u>Floor Standing Cabinet Air  Conditioner 4.0 Ton DC  Inverter (Heat &amp; Cool)</u></b></p> <ul style="list-style-type: none"> <li>• Compressor Type: Rotary-T3 Type</li> <li>• Refrigerant Type: R 410A</li> <li>• Low Voltage Operation Startup</li> <li>• Double Layer Condenser,</li> <li>• Pure Copper Installation Kit,</li> <li>• Rated Voltage 220-240V,</li> <li>• Cooling Capacity 48000 BTU with Maximum</li> </ul>	No	02			

	<p>Electricity Saving up-to 60%</p> <ul style="list-style-type: none"> <li>Efficient Cooling Performance even on 45 C</li> </ul> <p><b>Warranty: Compressor at least 03 Years, Parts Replacement 01 Year Gree, Haier or Equivalent Service Center/ Parts Availability: In Sahiwal</b></p>					
	<b>Grand Total (Rs.)</b>					
	<b>Grand Total in words with all Taxes, Installation and Delivery Charges</b>					

**Note:**

- The Purchase/Work order will be awarded on **Item Wise Basis.**
- Please clearly mention the quoted model/brand/technical detail otherwise your bid /items may be rejected.
- Bidders shall price the Bill of Quantities in Pakistani Rupees only.
- For all the Brands mentioned in this tender (if any), the term “or equivalent” is hereby added and shall be considered as per PPRA rules.
- Multiple prices of an item may lead to rejection of the item/bid.
- Please quote the rates on our BoQ otherwise your bid/item may be rejected.

**Sheet for Evaluation of Technical Proposals of the Vendors**

<b>Sr. No</b>	<b>Evaluation Criteria</b>	<b>Provided</b>
01	Literature of Quoted Brand	
02	Valid NTN & GST Numbers	
03	Active Taxpayer List	
04	Complete Company Profile including Year of Establishment and Client Lists	
05	Photocopies of Purchase Orders for Supply of Furniture/Fixtures to any Federal or Provincial Government Department, Agency, Organization or autonomous body or Private Sector Organization anywhere in Pakistan	
06	Warranty Acceptance Certificate	
07	Affidavit on Judicial Stamp Paper	



# Lay Out

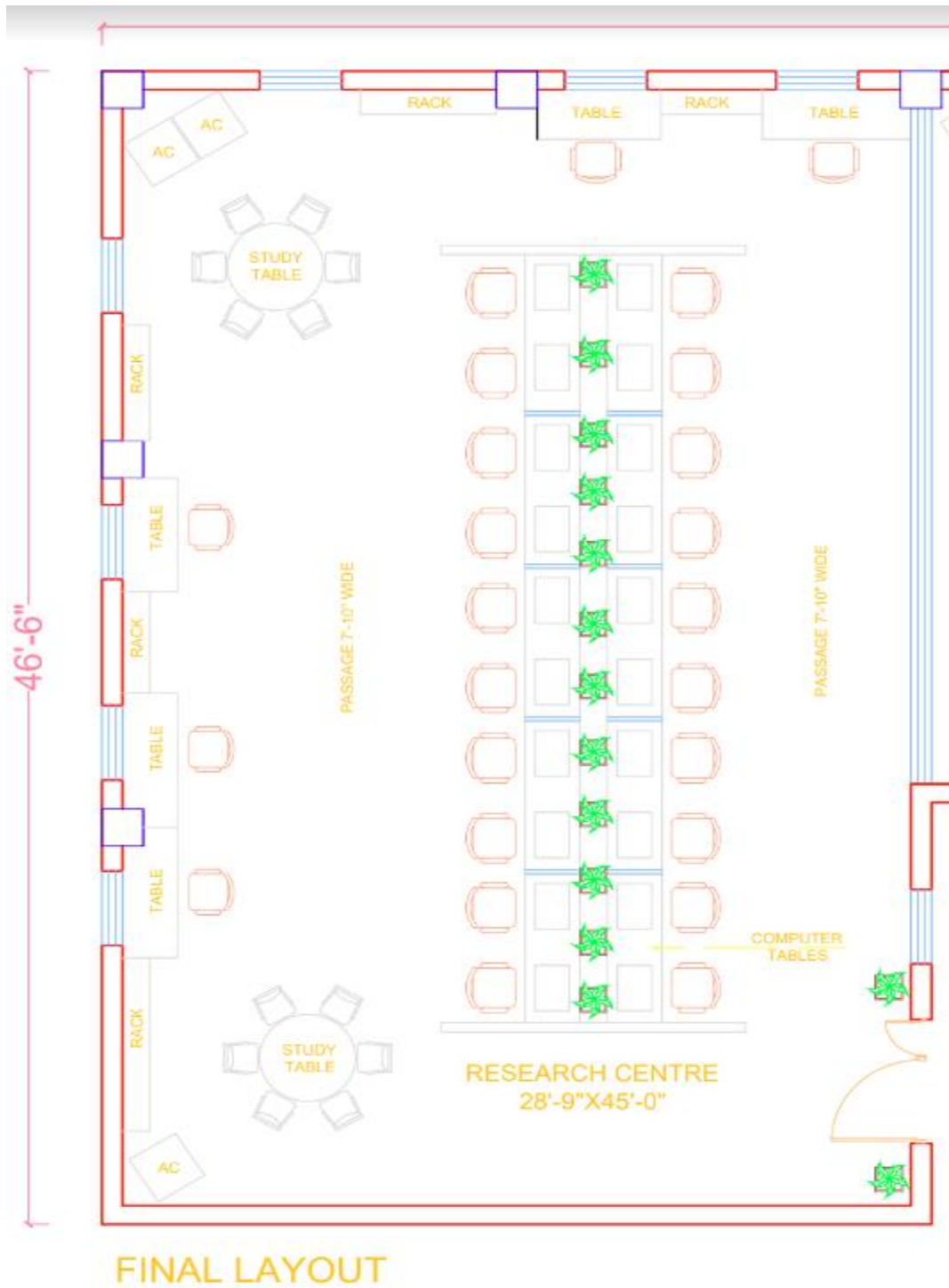

**Center Table**



**Round Table for Six Persons Qty-02**



**Table for One Person Qty-05**



**Revolving Chair (Qty 20)**



**Student Sitting Chair (Qty-17)**



**Books Shelves**

**Signature & Stamp of Bidder**

